

Article number: 2302168998

Description: E+G Stjernegreb VCRT.40 FP-M8

Measures

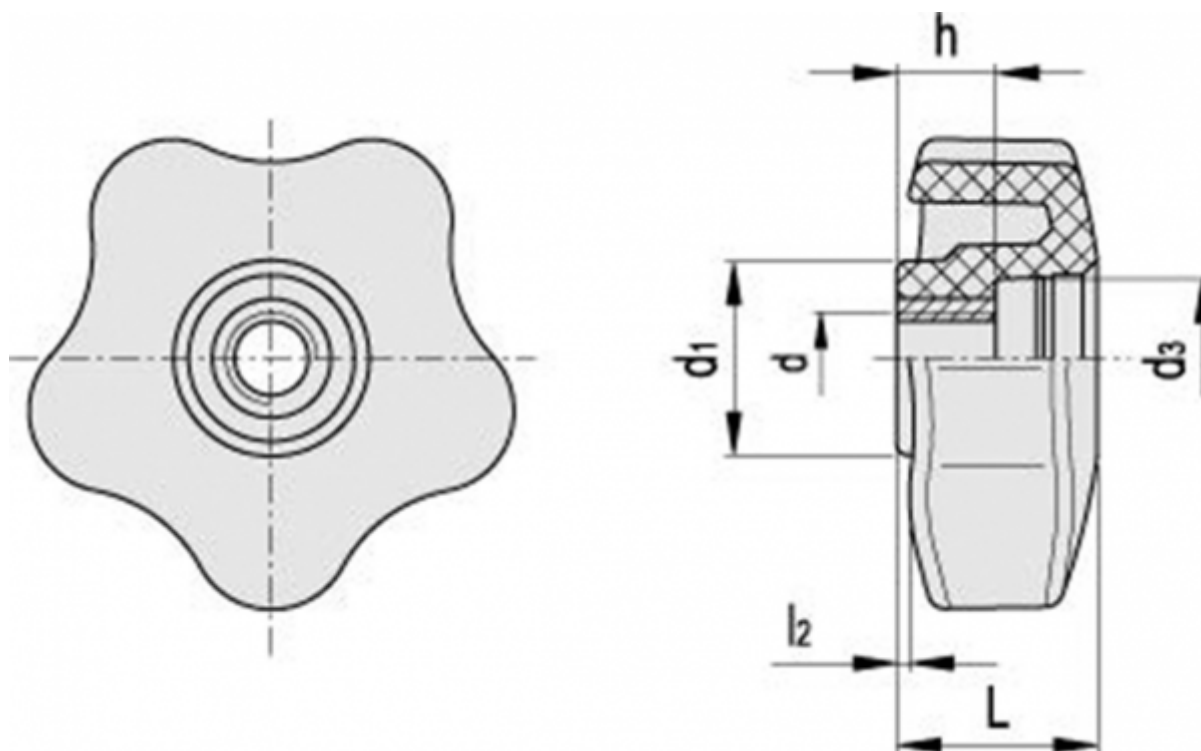

D	= 40
d1	= 17
d3	= 12.5
dh	= 8
h	= 10
l2	= 1
L	= 17
Weight in (g)	= 10